

## Substation Monitoring and Control through IOT

Om Prakash, Shilpi and Pratima Walde

School of Electrical, Electronics and Communication Engineering,  
 Galgotias University, Greater Noida, India

Date of Submission: 14-06-2020

Date of Acceptance: 30-06-2020

**ABSTRACT:** Power is generated at power plant and is used to be carried out by transmission line to the distribution substation. The substation steps down the voltage through the transformer and distributes it to the different area. We need to monitor the parameters of distribution line like current, voltage, power and temperature of the substation. So, we have made a system where we can monitor all these parameters on the LCD (Liquid Crystal Display) using IOT (Internet of Things) modules.

Then after suppose there is a fault in the distribution line say short circuit then we are making a system which can trip the particular distribution line in case of fault. After that alarm and indicator in the substation will become on alarm the people about the fault in the particular area where the fault has been occurred and fault will be sensed by using different types of sensors like current sensor(ACS 712), voltage sensor(25 V) and temperature sensor(LM 35).

**KEYWORDS:** Current Sensor, Voltage Sensor, Temperature Sensor and IOT.

### I. INTRODUCTION

Electricity is most advantageous form of energy which is used in today's industrial world. These systems consist of extremely nonlinear and intricate linkages [1]. The power station consists of generators, step down transformers, step up transformers, switches, loads and distribution lines. These all equipment has its own parameters which should be controlled and monitored manually to avoid any fault.

### II. OBJECTIVES

- To monitor and control all the parameters using IOT module in case of any fault.
- To display the status of distribution and in case of fault which type of fault has occurred.
- To interchange the power between two area if particular area has grid failure problem.

### III. LITERATURE SURVEY

**1. KrupalDhimar et al:** Their project aim was to control and monitor the electrical parameters voltage, current and frequency using through microcontroller and GSM (Global System for Mobile Communications). In this, they were controlling these parameters by the use of relay. The relay trips the whole current when the parameter exceeds their limit. The relay sends the message whenever it breaks the circuit.

**2. GhousBukshNarejo et al:** They enhanced this project by using GSM modem. They were making the whole system more intelligent and automated. This project helps in reducing labor cost and decreased time utility.

### IV. BLOCK DIAGRAM

It consist all representation of equipment used in this project.

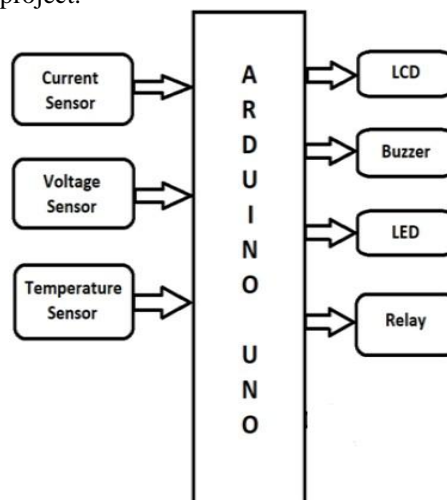

Fig.4.1. Block Representation of Circuit

### V. WORKING

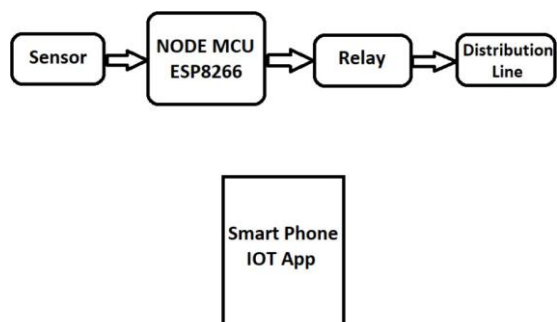

Fig.4.2.IOT Feature Block Representation

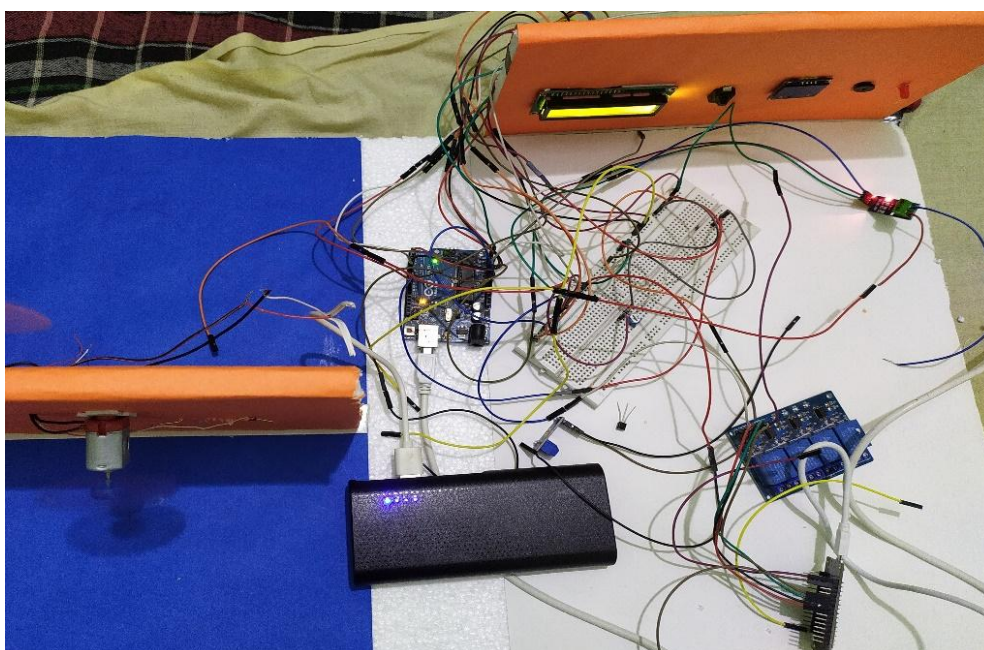
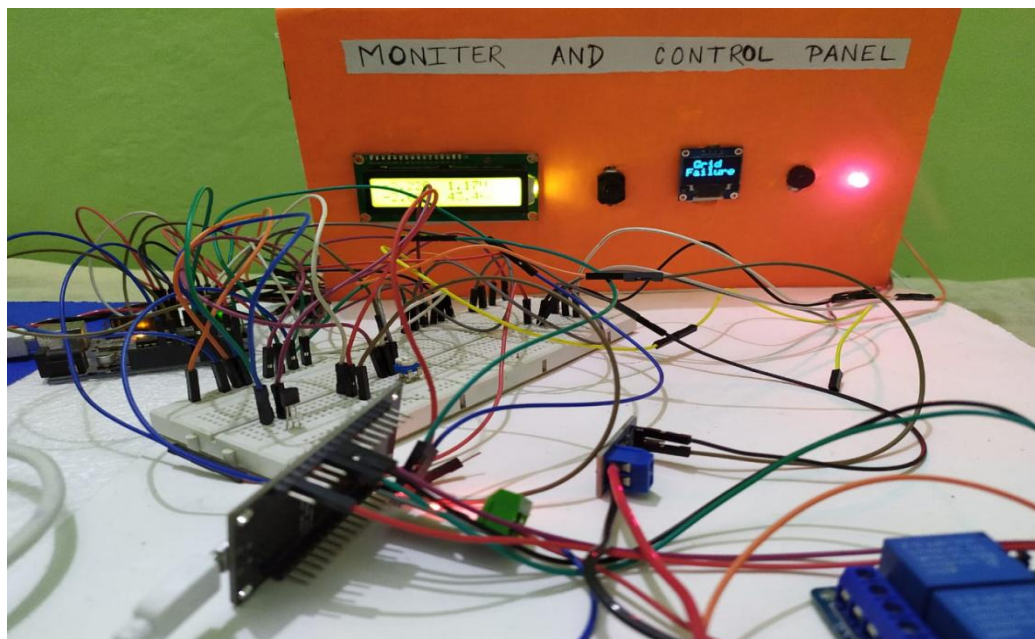

Figure.5.1. Substation Prototype Model

We installed different types of sensors for measuring different parameters like voltage sensor for measuring voltage, current sensor for computing current and temperature sensor for computing hotness respectively. We don't have any sensor for measuring power so power is being calculated from  $Power = Voltage (V) * Current (I) * P.F$  (Power Factor). These all

values will be given as input in Arduino and will convert them into analog form to digital form for processing. All these values of these parameters will be displayed on 16\*2 LCD Screen. It will be used to display these parameters which are current, voltage, power and temperature. This all process is Monitoring.



**Figure.5.2.Parameters value on LCD**

After that we need to control all these parameters in case of any fault occurred so to control these parameters we need to do proper coding in Arduino which will sense all these parameters and will take immediate reaction. We made a prototype so we are considering only open circuit parameters because short circuit parameters cannot be implemented in prototype. We assumed certain conditions to show the fault which will be displayed on OLED (Organic Light Emitting Diode) Screen. Conditions are as given below:

- **For short circuit**

If current is greater than the cut off value current, then relay of that particular area will be off.

- **For open circuit**

If current is less than the minimum value current, then the relay of that particular area will be off.

- **For very high voltage**

If voltage exceeds the cut off voltage, then the relay of that particular area will be off.

Relay will take immediate actions and it trips power distribution.

In order for controlling these parameters Arduino will give small signal to output devices like fan, buzzer and LED (Light Emitting Diode) which will alarm people on the substation. Suppose the certain distribution line of the certain area has been short circuited, short circuit leads to increase in the value of current. When the current value exceeded the certain level then the following will happen-

- Arduino will give signal to the relay to cut off the particular area electricity where fault has been occurred.
- Buzzer and indicator of the panel will become ON to alarm the people in the substation.
- Although Arduino will automatically cut off the power supply of the particular area. Then, also a cut OFF and ON which has been provided in the panel to manually cut OFF and ON the particular area distribution line.



**Figure.5.3.Showing IOT Controlling**

We implemented the system in such a way that it can be monitored and controlled from sitting anywhere in the world via IOT Module. We are using node MCU ESP8266 to control the relay and therefore electricity to distribution area through internet. We need to just have internet connection in our monitoring device and through IOT platform for IOT app, we can monitor the parameters of the transmission line being anywhere in the world. Node MCU ESP 8266 needs Wi-Fi (Wireless Fidelity) connection so that it can send and receive

**Coding for IOT Module (NODE MCUESP8266):**

```
#define BLYNK_PRINT Serial
#include <ESP8266WiFi.h>
#include <BlynkSimpleEsp8266_SSL.h>
// You should get Auth Token in the Blynk App.
// Go to the Project Settings (nut icon).
char auth[] = "IjC7_YuInNpZD3uL6oERPQei-zd8HYJr";
// Your WiFi credentials.
// Set password to "" for open networks.

char ssid[] = "Om";
char pass[] = "Om@prakash";
void setup()
{
  // Debug console
  Serial.begin(115200);
  Blynk.begin(auth, ssid, pass);
```

data to server. Through IOT in our phone, we can give command to trip down any distribution area in case we require to do so. Therefore, we can monitor and control without being physically present at the substation and being at any part of the world.

We developed our system in such a way that it will also allow power sharing between two areas in case one grid gets failed. It will maintain the continuity of power distribution.

```
}
void loop()
{
  Blynk.run();
}
```

## VI. RESULT AND DISCUSSIONS

Thus the system enables us to monitor and control the distribution in case of any fault. It has the system for control for tripping down the relay of line in case of fault and to normalize the line again after clearing the fault and to normalize the temperature of transformer and substation by cooling fan. This project measures the parameters of power substation and transformer and displays it on LCD display and will also send data to far distance placed wirelessly through GSM module (IOT). Thus, it can be monitored at substation as well as from far distant place.

We made a prototype so listing the comparative coding logic in below table:

Condition	Coding Comparative Value	Status Shown in Panel	Alarm and LED Indicator
For Normal Distribution	$V_{in} > \text{min. voltage} = 3$ $I = 0.5$	Distribution is normal	OFF
For Grid Failure Fault	$V_{in} < \text{min. voltage} = 3$	Grid Failure	ON
For Open Circuit Fault	$V_{in} < \text{min. voltage} = 3$ $I < \text{under current} = 0.5$	Open Circuit Fault	ON

**Table 6.1.**Comparative Coding Logic

Status	Current(A)	Voltage ( V )	Power ( W )	Temperature (°C)	Alarm & LED Indicator
Normal Distribution	3.85	5.03	19.35	25.39	OFF
Grid Failure	1.1	1.17	1.287	43.4	ON
Open Circuit	0.2	4.93	0.986	24.89	ON

**Table 6.2** Observed Reading

We tried to represent our observed reading through graph, below graph showing open circuit parameters like normal distribution, grid failure and open circuit:

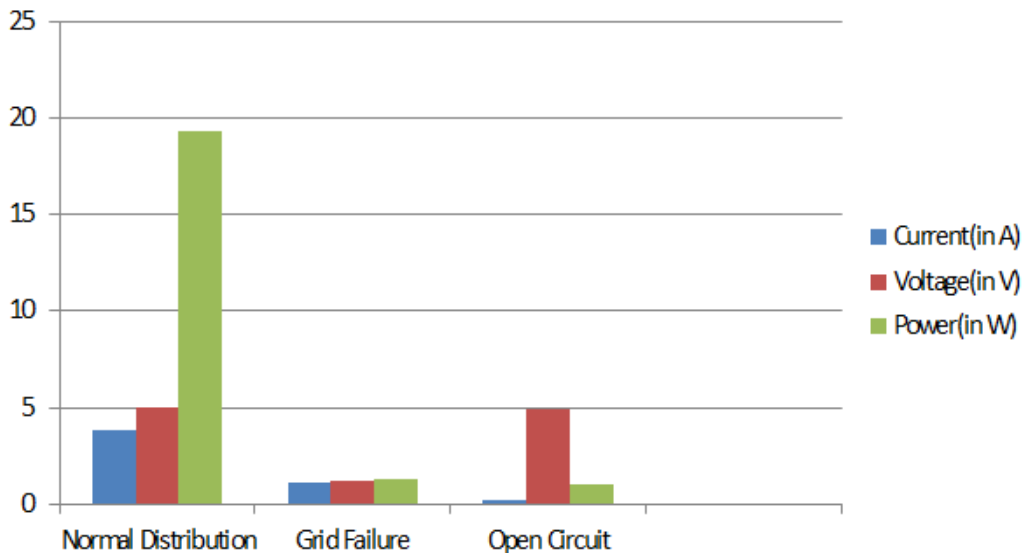

All these parameters will be controlled by using IOT module via Wi-Fi at sitting any corner of world.

## VII. CONCLUSIONS

We made a prototype for observing and adjusting the substation and transformer factors like voltage, current, power and temperature. All these considerations will be observed using Arduino. We went for programming in such a way that it can monitor all parameters and comparative coding logic is set so that when parameters goes

beyond the limit or below the limit it will tell fault occurred as described in coding logic, will be displayed on OLED Screen. All the output devices like buzzer, LED indicator will alarm the people sitting on substation. The automatic command will be given to trips the relay so that further destruction would stop.

We enhanced this by adding IOT module so that it can be monitored and controlled from sitting at any corner of the world.

We added one more feature of power supply sharing between two areas if grid of one

area gets failed as well as total cut off of power supply in case of emergency.

#### Future Works

Further we want to install cameras to visualize the parts and components like transformers, isolator, bus bar etc. of substation, so that it can be seen from any place of world.

#### REFERENCES

- [1]. JyotishmanPathak, Yuan Li, VasantHonavar and James D. McCalley, "A Service-Oriented Architecture for Electric Power Transmission System Asset Management", In ICSOC Workshops, pp: 26-37, 2006.
- [2]. B. A. Carreras, V. E. Lynch, D. E. Newman and I. Dobson, "Blackout Mitigation Assessment in Power Transmission Systems", Hawaii International Conference on System Science, January 2003.
- [3]. Xiaomeng Li and Ganesh K. Venayagamoorthy, "A Neural Network Based Wide Area Monitor for a Power System", IEEE Power Engineering Society General Meeting, Vol. 2, pp: 1455-1460, 2005.

Om Prakash, et. al. "Substation Monitoring and Control through IOT." *International Journal of Advances in Engineering and Management (IJAEM)*, 2(1), 2020, pp. 383-388.



**International Journal of Advances in  
Engineering and Management**

**ISSN: 2395-5252**



# IJAEM

**Volume: 02**

**Issue: 01**

**DOI: 10.35629/5252**

**[www.ijaem.net](http://www.ijaem.net)**

**Email id: [ijaem.paper@gmail.com](mailto:ijaem.paper@gmail.com)**